

DESIGN SHOWCASE

Large Capacitor Replaces Backup Battery

A large (0.1F) capacitor can replace your backup battery in certain applications. Though limited in storage capacity, the capacitor offers sufficient backup for low-dissipation equipment in which typical power outages last from a few seconds to several hours.

A simple implementation (Figure 1a) combines the capacitor with a battery-switchover IC—a device that monitors the supply and switches the load to battery voltage when the supply fails or “browns out.” As the following explanation attests, however, the simple approach can be unreliable when applied to the MAX690.

The capacitor charges rapidly to $V_{DD} - V_{BE}$. (V_{BE} is the diode’s forward-voltage drop, approximately 0.6V.) V_{BE} and the charging current then decrease exponentially as the large capacitor continues charging (toward V_{DD}) with a time constant ranging from many hours to several days. When the capacitor reaches full charge—typically within 0.2V of V_{DD} —the diode leakage equals the sum of leakages into the capacitor and the high-impedance input V_{BATT} . Low-leakage circuits can charge the capacitor nearly to V_{DD} .

This proximity of battery voltage (V_{BATT}) to V_{DD} creates a problem, because the IC initiates a switchover whenever V_{DD} plus a small offset is less than V_{BATT} . Switchovers imply power failures, but this circuit will switch in response to the normal V_{DD} fluctuations caused by variations in line, load, and temperature.

Adding a large resistor across the capacitor solves the problem by assuring the typical V_{BE} drop of 0.6V, but the resistor also accelerates discharge during the backup condition. Even a large (10M Ω) resistor cuts the backup time in half.

An improved version of the backup circuit (Figure 1b) includes a blocking diode (D_2) that prevents discharge through the resistor during backup. The resistor can be smaller because its current comes only from the main supply. As before, this current keeps the diode forward-biased, maintaining a safety margin of one V_{BE} against droop in the V_{DD} supply. You can increase the margin by adding diodes in series with D_1 .

A further improvement (Figure 1c) replaces D_1 with R_2 and D_2 with Q_1 . The resistor divider lets you set the backup voltage (V_x) as desired.

(Circle 6)

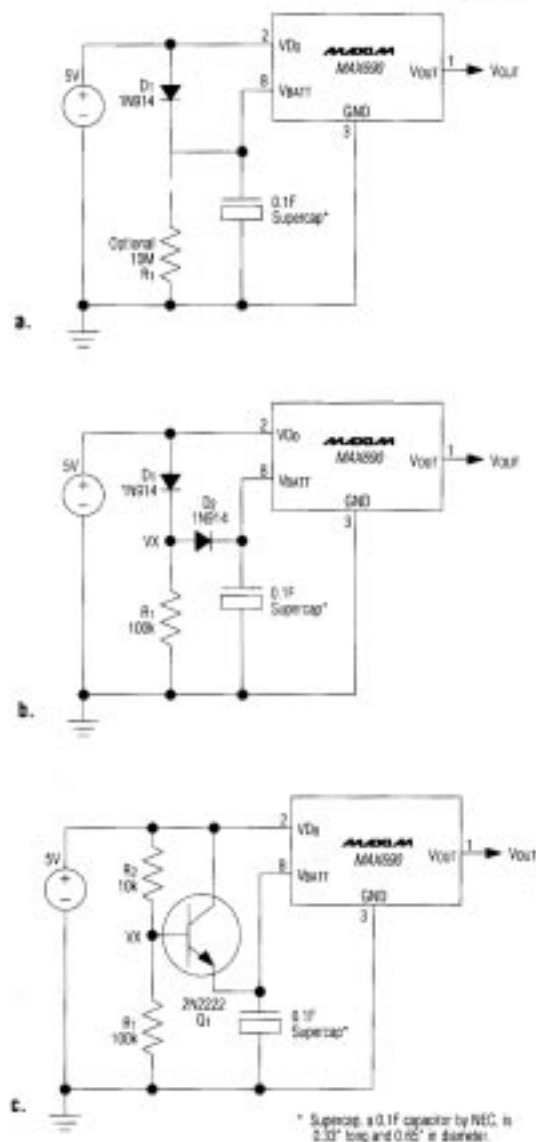

Figure 1. Battery-switchover circuits offer performance vs. cost and complexity: The simple version (a) may switch excessively. Curing that problem with a blocking diode (b) delays the backup protection following power-up. Introducing a transistor (c) lets you set the backup voltage as desired.